

# Pfaff 1246 Subclass

# PFAFF

## 1246

**Unterklassen-Ausstattung**

Subclass parts

Composition des sous-classes

Composición de las subclases

# 16.03

Unterklassen-Ubersicht  
Table of subclasses  
Table de sous-classes  
Tabla de subclases

PFAFF 1246-706/07

Unterklasse Subclass Sous-classe Subclase	-6/01 ▲	-6/01 ▲	-6/01 ▲	-6/01-900/.. ▲
Arbeitsgang Operation Opération Operación	Für allgemeine Näharbeiten. Standardform des Teilesatzes. For ordinary sewing operations. Standard part set. Travaux d'utilité courante. Jeu de pièces standard. Para trabajos de costura en general. Juego de piezas estándar.	Für allgemeine Näharbeiten. Standardform des Teilesatzes. For ordinary sewing operations. Standard part set. Travaux d'utilité courante. Jeu de pièces standard. Para trabajos de costura en general. Juego de piezas estándar.	Für allgemeine Näharbeiten. Standardform des Teilesatzes. For ordinary sewing operations. Standard part set. Travaux d'utilité courante. Jeu de pièces standard. Para trabajos de costura en general. Juego de piezas estándar.	Für allgemeine Näharbeiten. Standardform des Teilesatzes. For ordinary sewing operations. Standard part set. Travaux d'utilité courante. Jeu de pièces standard. Para trabajos de costura en general. Juego de piezas estándar.
Ausführung Model Version Tipo de máquina	BN	CN	CN8	BN
Nadelabstand in mm Needle gauge in mm Ecartement des aiguilles en mm Distancia entre agujas en mm	2,4 - 50,0	3,2 - 50,0	3,2 - 50,0	3,2 - 32,0
Nadelstange <sup>10/2</sup> Needle bar Barre à aiguille Barra de aguja	91-710 749-93 <sup>10</sup> = 2,4 - 34,0 mm 91-710 750-93 <sup>10</sup> = 36,0 - 50,0 mm	91-710 749-93 <sup>10</sup> = 3,2 - 34,0 mm 91-710 750-93 <sup>10</sup> = 36,0 - 50,0 mm	91-710 749-93 <sup>10</sup> = 3,2 - 34,0 mm 91-710 750-93 <sup>10</sup> = 36,0 - 50,0 mm	91-710 749-93
Stoffdrückerfuß <sup>4</sup> <sup>10/2</sup> Presser foot Pied presseur Pie prensatelas	91-040 429-04	91-040 429-04	91-049 668-04	91-040 429-04
Stoffschiefbefuß <sup>4</sup> <sup>10/2</sup> Vibrating presser Pied entraîneur Transportador superior	91-049 267-93	91-049 267-93	91-049 267-93	91-049 267-93
Stichplatte <sup>4</sup> <sup>10/1</sup> <sup>10/2</sup> Needle plate Plaque à aiguille Placa de aguja	91-040 434-04	91-040 434-04	91-158 601-04	91-058 945-04
Stoffschieber <sup>4</sup> <sup>10/1</sup> Feed dog Griffe Transportador inferior	91-040 433-04 <sup>10</sup> = 2,4 - 34,0 mm 91-047 275-93 <sup>10</sup> = 38,0 - 50,0 mm	91-040 433-04 <sup>10</sup> = 3,2 - 36,0 mm 91-047 275-93 <sup>10</sup> = 38,0 - 50,0 mm	91-040 433-04 <sup>10</sup> = 3,2 - 36,0 mm 91-047 275-93 <sup>10</sup> = 38,0 - 50,0 mm	91-040 433-04
Fingerschutz Finger guard Protège-doigts Salvadedos	91-057 721-91 <sup>10</sup> = 2,4 - 4,4 mm 91-057 722-91 <sup>10</sup> = 4,8 - 15,2 mm 91-057 723-91 <sup>10</sup> = 16,0 - 30,0 mm 91-057 724-91 <sup>10</sup> = 32,0 - 50,0 mm	91-057 721-91 <sup>10</sup> = 3,2 - 4,4 mm 91-057 722-91 <sup>10</sup> = 4,8 - 15,2 mm 91-057 723-91 <sup>10</sup> = 16,0 - 30,0 mm 91-057 724-91 <sup>10</sup> = 32,0 - 50,0 mm	91-057 721-91 <sup>10</sup> = 3,2 - 4,4 mm 91-057 722-91 <sup>10</sup> = 4,8 - 15,2 mm 91-057 723-91 <sup>10</sup> = 16,0 - 30,0 mm 91-057 724-91 <sup>10</sup> = 32,0 - 50,0 mm	91-057 721-91 <sup>10</sup> = 3,2 - 4,4 mm 91-057 722-91 <sup>10</sup> = 4,8 - 15,2 mm 91-057 723-91 <sup>10</sup> = 16,0 - 30,0 mm 91-057 724-91 <sup>10</sup> = 32,0 mm
Apparat <sup>5</sup> Attachment Appareil Aparato				
Schieber, links <sup>10/2</sup> Slide, left Glissière, gauche Corredera, izquierda	91-018 889-24	91-018 889-24	91-018 889-24	91-018 889-24
Schieber, rechts <sup>10/2</sup> Slide, right Glissière, droite Corredera, derecha	91-010 061-24	91-010 061-24	91-010 061-24	91-018 888-24
Träger Bracket Support Soporte				
Bandführung Tape guide Guide-ruban Guicintas				
<p>▲ Nähwerkzeuge für Maschinen mit und ohne Hüpftransport. Part set for machines with and without four-motion drop feed. Organes de couture pour machines avec et sans griffe santillante. Organos de couture para máquinas con y sin transporte a cuatro tiempos.</p>				

Unterklassen-Übersicht



Table of subclasses

Table de sous-classes





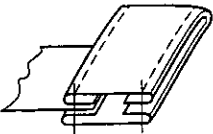
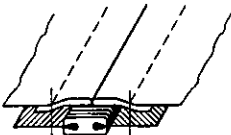
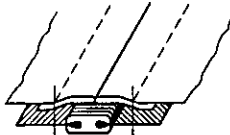

Tabla de subclases

PFAFF 1246-706/07

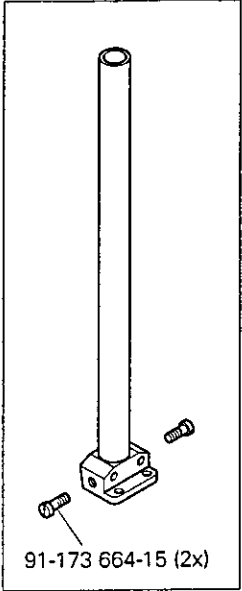
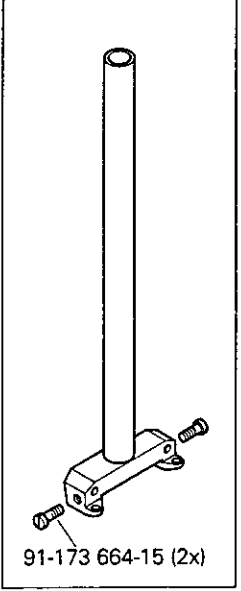
16.03

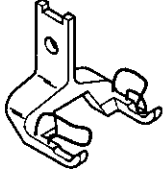
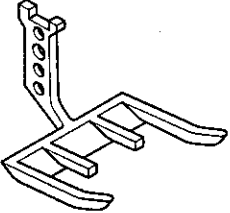
Unterklasse Subclass Sous-classe Subclase	-6/01-900/.. ▲	-6/01-900/.. ▲	-63/03 ▲	-63/03-900/.. ▲
Arbeitsgang Operation Opération Operación	Für allgemeine Näharbeiten. Standardform des Teilesatzes. For ordinary sewing operations. Standard part set. Travaux d'utilité courante. Jeu de pièces standard. Para trabajos de costura en general. Juego de piezas estándar.	Für allgemeine Näharbeiten. Standardform des Teilesatzes. For ordinary sewing operations. Standard part set. Travaux d'utilité courante. Jeu de pièces standard. Para trabajos de costura en general. Juego de piezas estándar.		
Ausführung Model Version Tipo de máquina	CN	CN8	CN	CN
Nadelabstand in mm Needle gauge in mm Ecartement des aiguilles en mm Distancia entre agujas en mm	3,2 - 32,0	3,2 - 32,0	3,2 - 20,0	3,2 - 20,0
Nadelstange <sup>10/2</sup> Needle bar Barre à aiguille Barra de aguja	91-710 749-93	91-710 749-93	91-710 749-93	91-710 749-93
Stoffdrückerfuß <sup>4</sup> <sup>10/2</sup> Presser foot Pied presseur Pie prensateelas	91-040 429-04	91-049 668-04	91-049 509-04	91-049 509-04
Stoffschiebefuß <sup>4</sup> <sup>10/2</sup> Vibrating presser Pied entraineur Transportador superior	91-049 267-93	91-049 267-93	91-049 017-93	91-049 017-93
Stichplatte <sup>4</sup> <sup>10/1</sup> <sup>10/2</sup> Needle plate Plaque à aiguille Placa de aguja	91-058 943-04	91-158 602-04	91-040 434-04	91-058 943-04
Stoffschieber <sup>4</sup> <sup>10/1</sup> Feed dog Griffe Transportador inferior	91-047 934-04	91-047 934-04	91-047 934-04	91-047 934-04
Fingerschutz Finger guard Protège-doigts Salvadedos	91-057 721-91 <sup>10</sup> = 3,2 - 4,4 mm 91-057 722-91 <sup>10</sup> = 4,8 - 15,2 mm 91-057 723-91 <sup>10</sup> = 16,0 - 30,0 mm 91-057 724-91 <sup>10</sup> = 32,0 mm	91-057 741-91 <sup>10</sup> = 3,2 - 4,4 mm 91-057 806-91 <sup>10</sup> = 4,8 - 15,2 mm 91-057 809-91 <sup>10</sup> = 16,0 - 30,0 mm 91-057 812-91 <sup>10</sup> = 32,0 mm		
Apparat <sup>5</sup> Attachment Appareil Aparato			91-042 369-21	91-042 369-21
Schieber, links <sup>10/2</sup> Slide, left Glissière, gauche Corredera, izquierda	91-018 889-24	91-018 889-24	91-018 889-24	91-018 889-24
Schieber, rechts <sup>10/2</sup> Slide, right Glissière, droite Corredera, derecha	91-018 888-24	91-018 888-24	91-010 061-24	91-018 888-24
Träger Bracket Support Soporte			91-041 644-91	91-041 644-91
Bandführung Tape guide Guide-ruban Guiacintas			91-044 419-25	91-044 419-25
<p>▲ Nähwerkzeuge für Maschinen mit und ohne Hüpftransport. Part set for machines with and without four-motion drop feed. Organes de couture pour machines avec et sans griffe sautillante. Organos de couture para máquinas con y sin transporte a cuatro tiempos.</p>				

Unterklasse Subclass Sous-classe Subclase	-68/99 ▲	-230/21 ▲	-230/21-900/.. ▲
Arbeitsgang Operation Opération Operación			
Ausführung Model Version Tipo de máquina	BN	CN	CN
Nadelabstand in mm Needle gauge in mm Écartement des aiguilles en mm Distancia entre agujas en mm	30,0 - 40,0	8,0 - 30,0	8,0 - 30,0
Nadelstange <sup>10/2</sup> Needle bar Barre à aiguille Barra de aguja	91-710 749-93 <sup>10</sup> = 30,0 - 34,0 mm 91-710 750-93 <sup>10</sup> = 36,0 - 40,0 mm	91-710 749-93	91-710 749-93
Stoffdrückerfuß <sup>4</sup> <sup>10/2</sup> Presser foot Pied presseur Pie prensatelas	91-049 708-04	91-049 503-03 <sup>5</sup>	91-049 503-03 <sup>5</sup>
Stoffschiebefuß <sup>4</sup> <sup>10/2</sup> Vibrating presser Pied entraîneur Transportador superior	91-049 276-93	91-049 144-93 <sup>5</sup>	91-049 144-93 <sup>5</sup>
Stichplatte <sup>4</sup> <sup>10/1</sup> <sup>10/2</sup> Needle plate Plaque à aiguille Placa de aguja	91-040 434-04	91-040 434-04	91-058 943-04
Stoffschieber <sup>4</sup> <sup>10/1</sup> Feed dog Griffe Transportador inferior	91-040 433-04 <sup>10</sup> = 30,0 - 36,0 mm 91-047 275-93 <sup>10</sup> = 38,0 - 40,0 mm	91-040 433-04	91-047 934-04
Fingerschutz Finger guard Protège-doigts Salvadedos	91-057 723-91 <sup>10</sup> = 30,0 mm 91-057 724-91 <sup>10</sup> = 32,0 - 40,0 mm		
Apparat <sup>5</sup> Attachment Appareil Aparato	99-116 630-23	91-053 537-24	91-053 537-24
Schieber, links <sup>10/2</sup> Slide, left Glissière, gauche Corredera, izquierda	91-018 889-24	91-018 889-24	91-018 889-24
Schieber, rechts <sup>10/2</sup> Slide, right Glissière, droite Corredera, derecha	91-010 061-24	91-010 061-24	91-018 888-24
Träger Bracket Support Soporte			
Bandführung Tape guide Guide-ruban Guiacintas			
<p>▲ Nähwerkzeuge für Maschinen mit und ohne Hüpftransport. Part set for machines with and without four-motion drop feed. Organes de couture pour machines avec et sans griffe sautillante. Organos de couture para máquinas con y sin transporte a cuatro tiempos.</p>			

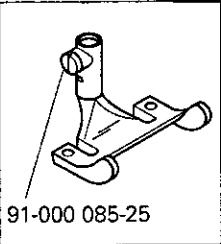
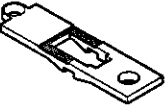
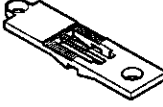
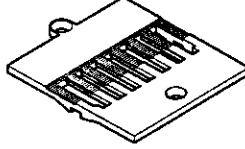
<p>91-710 749-93 <span style="border: 1px solid black; padding: 0 2px;">4</span> <span style="border: 1px solid black; padding: 0 2px;">10/2</span></p>  <p>91-173 664-15 (2x)</p> <p>-6/01 (-900/..)                  -63/03 (-900/..)                  -68/99                  -230/21 (-900/..)</p>	<p>91-710 750-93 <span style="border: 1px solid black; padding: 0 2px;">4</span> <span style="border: 1px solid black; padding: 0 2px;">10/2</span></p>  <p>91-173 664-15 (2x)</p> <p>-6/01                  -68/99</p>	<p>91-040 429-04 <span style="border: 1px solid black; padding: 0 2px;">4</span> <span style="border: 1px solid black; padding: 0 2px;">10/2</span></p>  <p>-6/01 (-900/..) BN; CN</p>	<p>91-049 503-03 <span style="border: 1px solid black; padding: 0 2px;">4</span> <span style="border: 1px solid black; padding: 0 2px;">10/2</span></p>  <p>-230/21 (-900/..)</p>
<p>91-049 708-04 <span style="border: 1px solid black; padding: 0 2px;">4</span> <span style="border: 1px solid black; padding: 0 2px;">10/2</span></p>  <p>-68/99</p>	<p>91-049 017-93 <span style="border: 1px solid black; padding: 0 2px;">4</span> <span style="border: 1px solid black; padding: 0 2px;">10/2</span></p>  <p>91-000 085-25</p> <p>-63/03 (-900/..)</p>	<p>91-049 144-93 <span style="border: 1px solid black; padding: 0 2px;">4</span> <span style="border: 1px solid black; padding: 0 2px;">10/2</span></p>  <p>91-000 085-25</p> <p>-230/21 (-900/..)</p>	<p>91-049 267-93 <span style="border: 1px solid black; padding: 0 2px;">4</span> <span style="border: 1px solid black; padding: 0 2px;">10/2</span></p>  <p>91-000 085-25</p> <p>-6/01 (-900/..)</p>
<p>91-049 276-93 <span style="border: 1px solid black; padding: 0 2px;">4</span> <span style="border: 1px solid black; padding: 0 2px;">10/2</span></p>  <p>91-000 085-25</p> <p>-68/99</p>	<p>91-040 434-04 <span style="border: 1px solid black; padding: 0 2px;">4</span> <span style="border: 1px solid black; padding: 0 2px;">10/2</span></p> <p><span style="border: 1px solid black; padding: 0 2px;">10</span> = B 2.4 - 4.0 mm                  C 3.2 - 6.4 mm</p>  <p>-6/01 BN; CN                  -63/03 CN</p>	<p>91-040 434-04 <span style="border: 1px solid black; padding: 0 2px;">4</span> <span style="border: 1px solid black; padding: 0 2px;">10/1</span> <span style="border: 1px solid black; padding: 0 2px;">10/2</span></p> <p><span style="border: 1px solid black; padding: 0 2px;">10</span> = B 4.8 mm &gt;                  C 7.2 mm &gt;</p>  <p>-6/01 BN; CN                  -63/03 CN                  -68/99 BN                  -230/21 CN</p>	<p>91-040 434-04 <span style="border: 1px solid black; padding: 0 2px;">4</span> <span style="border: 1px solid black; padding: 0 2px;">10/1</span> <span style="border: 1px solid black; padding: 0 2px;">10/2</span></p> <p><span style="border: 1px solid black; padding: 0 2px;">10</span> = 38.0 - 50.0 mm</p>  <p>-6/01 BN; CN                  -63/03 CN                  -68/99 BN</p>

# 16.04

Nähwerkzeuge  
 Gauge parts  
 Organes de couture  
 Organos de costura PFAFF 1246-706/07

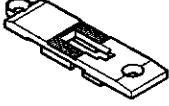
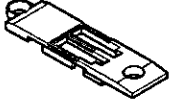
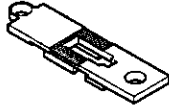
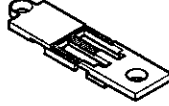
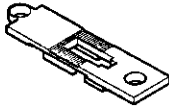
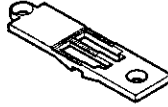
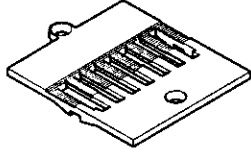
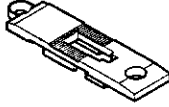
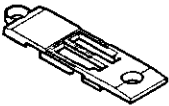
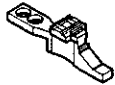
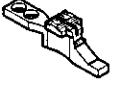
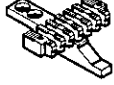
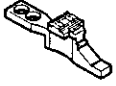
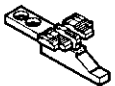
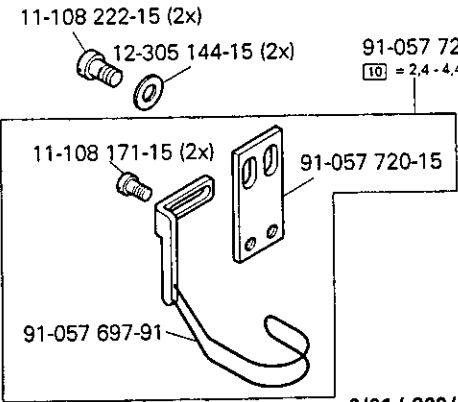
<p>91-058 943-04     = C 3,2 - 6,4 mm</p>  <p>-6/01-900/.. CN  -63/03-900/.. CN</p>	<p>91-058 943-04      = C 7,2 mm &gt;</p>  <p>-6/01-900/.. CN  -63/03-900/.. CN  -230/21-900/.. CN</p>	<p>91-058 945-04     = B 3,2 - 4,0 mm</p>  <p>-6/01-900/.. BN</p>	<p>91-058 945-04      = B 4,8 mm &gt;</p>  <p>-6/01-900/.. BN</p>
<p>91-158 601-04     = C 3,2 - 6,4 mm</p>  <p>-6/01 CN 8</p>	<p>91-158 601-04      = C 7,2 mm &gt;</p>  <p>-6/01 CN 8</p>	<p>91-158 601-04      = B 38,0 - 50,0 mm</p>  <p>-6/01 CN 8</p>	<p>91-158 602-04     = C 3,2 - 6,4 mm</p>  <p>-6/01-900/.. CN 8</p>
<p>91-158 602-04      = C 7,2 mm &gt;</p>  <p>-6/01-900/.. CN 8</p>	<p>91-040 433-04     = B 2,4 - 4,0 mm  C 3,2 - 6,4 mm</p>  <p>-6/01 BN; CN; CN 8  -6/01-900/.. BN  -63/03 CN</p>	<p>91-040 433-04      = B 4,8 mm  C 7,2 mm</p>  <p>-6/01 BN; CN; CN 8  -6/01-900/.. BN  -63/03 CN  -68/99 BN</p>	<p>91-047 275-93      = C 3,2 - 6,4 mm</p>  <p>-6/01 BN; CN; CN 8  -68/99 BN</p>
<p>91-047 934-04     = C 3,2 - 6,4 mm</p>  <p>-6/01-900/.. CN; CN 8  -63/03-900/.. CN</p>	<p>91-047 934-04      = C 7,2 mm &gt;</p>  <p>-6/01-900/.. CN; CN 8  -63/03-900/.. CN  -230/21-900/.. CN</p>	 <p>11-108 222-15 (2x)  12-305 144-15 (2x)  91-057 721-91   = 2,4 - 4,4 mm  11-108 171-15 (2x)  91-057 720-15  91-057 697-91  -6/01 (-900/..) BN; CN</p>	

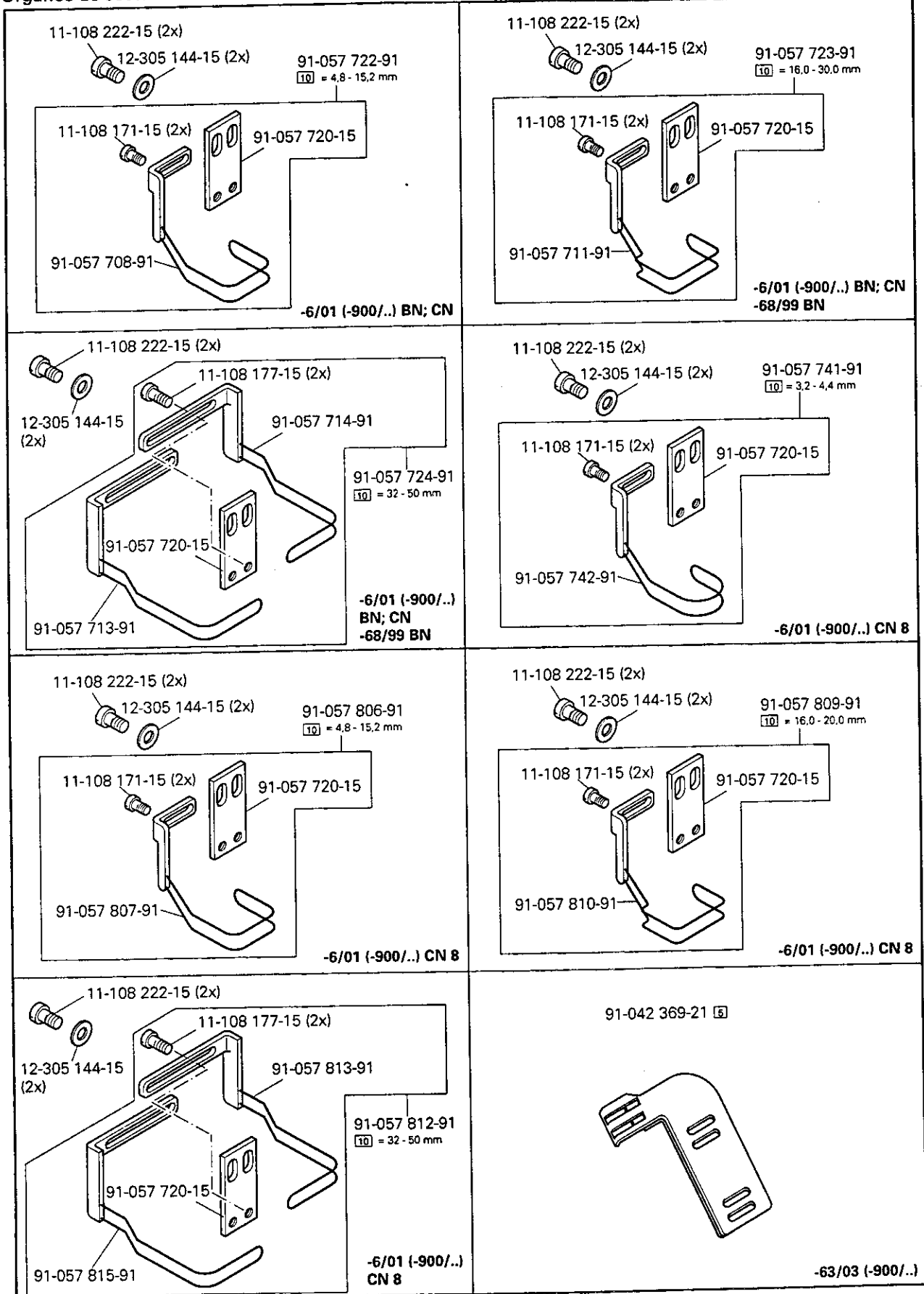





# 16.04

Nähwerkzeuge  
Gauge parts  
Organes de couture  
Organos de costura PFAFF 1246-706/07

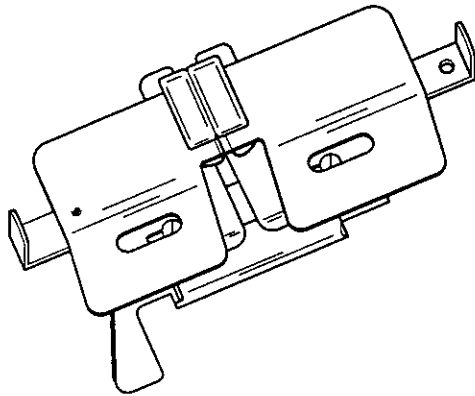
91-053 537-24 



-230/21 (-900/..)

91-000 521-25 



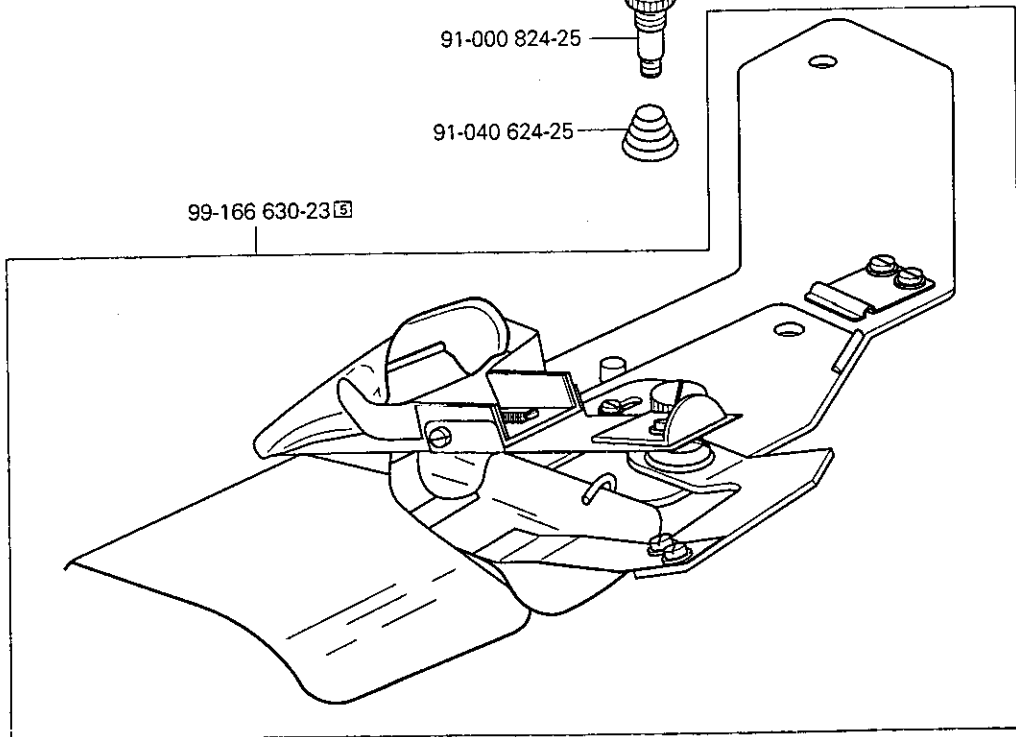

91-000 824-25 

91-040 624-25 

99-166 630-23 

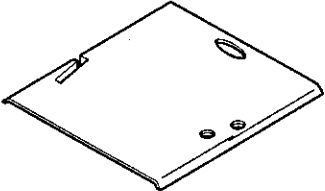

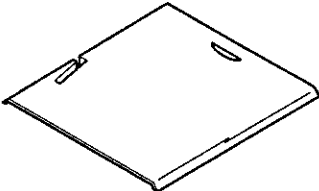
-68/99

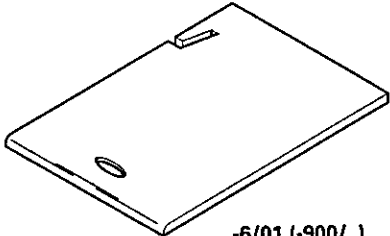
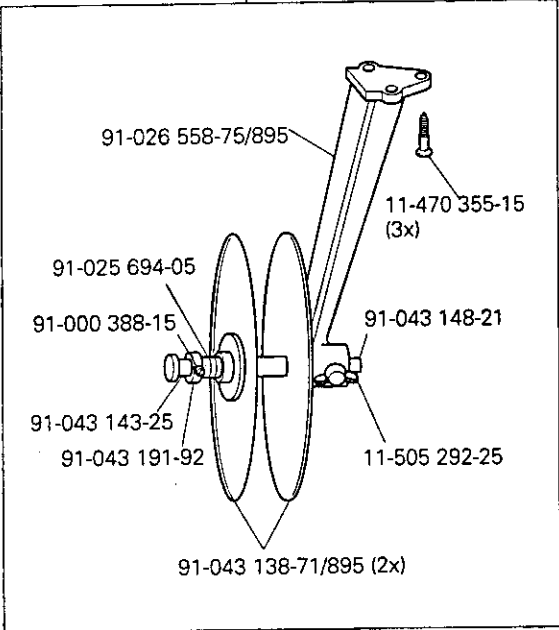
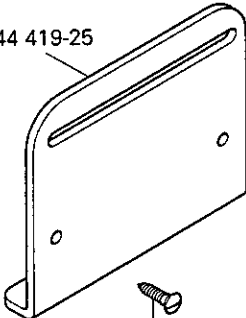
<p>91-010 061-24 </p>  <p>-6/01          -63/03          -68/99          -230/21</p>	<p>91-018 888-24 </p>  <p>-6/01-900/..          -63/03-900/..          -230/21-900/..</p>	<p>91-018 889-24 </p>  <p>-6/01 (-900/..          -63/03 (-900/..          -68/99          -230/21 (-900/..)</p>
<p>91-041 644-70/895</p>  <p>-63/03 (-900/..)</p>		<p>91-044 419-25</p>  <p>11-470 109-25 (2x)</p> <p>-63/03 (-900/..)</p>
<p>Blank area for additional parts or diagrams.</p>		<p>Blank area for additional parts or diagrams.</p>